

**The Birkin S3**  
**Component Build Manual**

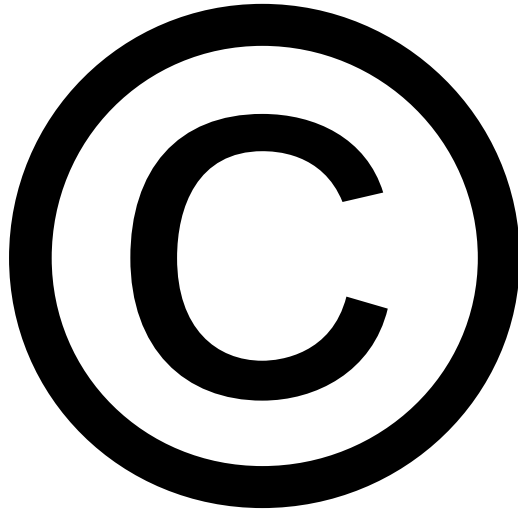



# COPYRIGHT

1st Edition

---

© 2000 BIRKIN EUROPE LIMITED

---

All rights reserved. No part of this manual may be reproduced or transmitted in any form or by any means, electronic or mechanical, including photocopying, recording or by any information storage or retrieval system, without permission in writing from the copyright holder.

---

While every attempt is made to ensure that the information in this manual is correct, no liability can be accepted by the authors, publishers or copyright owners for loss, damage or injury caused by any errors in, or omissions from, the information given.

---

BIRKIN EUROPE LIMITED T/A BIRKIN INTERNATIONAL, Ch de Trois - Portes 2006 Neuchatel Switzerland











---

# CONTENTS

---

<b>Preface</b>	<b>I</b>
<b>How to use this Manual</b>	<b>I</b>
<b>An Introduction to Fasteners, Tools and the Working Environment</b>	<b>II</b>
<b>Recommended Chassis Support Stands</b>	<b>III</b>
<b>Conversion Factors</b>	<b>IV</b>

---

<b>Group 1</b> Body Chassis	
<b>Group 2</b> Steering and Pedals	
<b>Group 3</b> Front Suspension	
<b>Group 4</b> Rear Suspension	
<b>Group 5</b> Chassis Accessories	
<b>Group 6</b> Lights	
<b>Group 7</b> Windscreen, Wiper and Mirror Kit	
<b>Group 8</b> Upholstery and Interior	
<b>Group 9</b> Weather Equipment	
<b>Group 10</b> Optional Extras	

---

# PREFACE

Congratulations on purchasing a Birkin S3 Component build project and welcome to the world of the Birkin! This is an opportunity for you, the enthusiast to build and add your personal touches to this unique sports car.

The purpose of this build manual is to guide you step by step with detailed pictures and easy to read script whilst building the car of your dreams. Although the manual has been compiled in consultation with the factory assembly personnel, it has been published with the enthusiast in mind, keeping steps simple and technical 'lingo' to a minimum.

## HOW TO USE THIS MANUAL

The manual is divided into 10 colour coded chapters to coincide with the component Groups available. It is then split up into further sections which approach separately the various assemblies found within the Group. All parts relevant to the sections are pictured on the first page of each Group.

As important information relating to a step is often found just after it, it is important to read the whole of each section carefully before starting assembly.



**This Nota Bena sign is placed next to text which indicates important information which is necessary to properly complete a procedure or make it easier to understand. It may also provide information on special procedures which if not followed may result in damage to the assembly or personal injury.**

This manual is written in the order that each group should be bought and assembled, starting with Group 1 - Body Chassis and ending with Group 10 - Optional Extras.

Whilst every attempt is made to ensure that the information in this manual is correct, no liability can be accepted by the authors, publishers or copyright owners for loss, damage or injury caused by any errors in, or omissions from, the information given.

# AN INTRODUCTION TO FASTENERS, TOOLS AND THE WORKING ENVIRONMENT.

## FASTENERS

These are nuts, bolts, screws and press studs used to hold two or more parts together. Threaded fasteners need to be kept clean and straight with undamaged threads and undamaged corners on the hex head where the wrench / spanner fits. If special locknuts with nylon or fibre inserts are removed after they have been torqued, they may lose their locking ability and should be replaced.

Should a fastener need to be replaced, it is important to read the information that follows whilst referring to the diagrams on the next page.

### FASTENER SIZES AND STRENGTHS.

Although the Birkin is essentially constructed using Metric bolts and cap screws, various components utilise standard USS or SAE fasteners. It is important therefore, to be able to tell the difference between these formats as they cannot be interchanged. A basic identification between the two formats may be made by observing the different grade markings on the bolt heads as shown overleaf.

In this manual all bolts and cap screws are sized according to diameter and length. For example, an “M8x31” bolt or cap screw is Metric with a diameter of 8mm and a length of 31mm. A ½x1 bolt is standard USS or SAE with a diameter of half an inch and a length of one inch. (Metric is measured in millimetres and Standard USS or SAE are measured in inches.)

Should the need for replacement occur, the fastener supplier may require details of the thread pitch. If the damaged original cannot be shown to the supplier, the thread pitch may be calculated in the following ways:

The thread pitch of a standard USS or SAE bolt or cap screw is the number of threads counted per inch. The thread pitch of a metric fastener is calculated using a vernier caliper, the distance between threads. Examples of thread pitch are indicated as “T” in the diagram overleaf.

Fasteners of the same size (both standard and metric) may have different strength ratings therefore, it is important when removing any threaded fasteners from your Birkin that they be reinstalled in their original locations. If the need for replacement occurs, please ensure the new fastener has a strength rating equal to or greater than the original.

Examples of grade markings indicating bolt strengths are shown in the diagram overleaf.

### TIGHTENING PROCEDURES

Almost all treaded fasteners need to be tightened to a specified torque value (torque is the twisting force applied to a threaded component). Over tightening can cause the fastener to weaken and break while under tightening can cause it to eventually work loose.

Threaded fasteners, depending their material and thread diameters, have specific torque values. Be sure to follow the torque recommendations specified throughout the manual closely.



Fastener suppliers may supply reference torque settings with replacements. However, as settings can differ according to the material to which the fastener is applied, it is important that you use only the torque settings stipulated to the relevant fasteners applications in the procedures of this manual.

# DIAGRAM SHOWING POSITION OF GRADE MARKINGS ON VARIOUS FASTENERS

## METRIC CAP SCREW

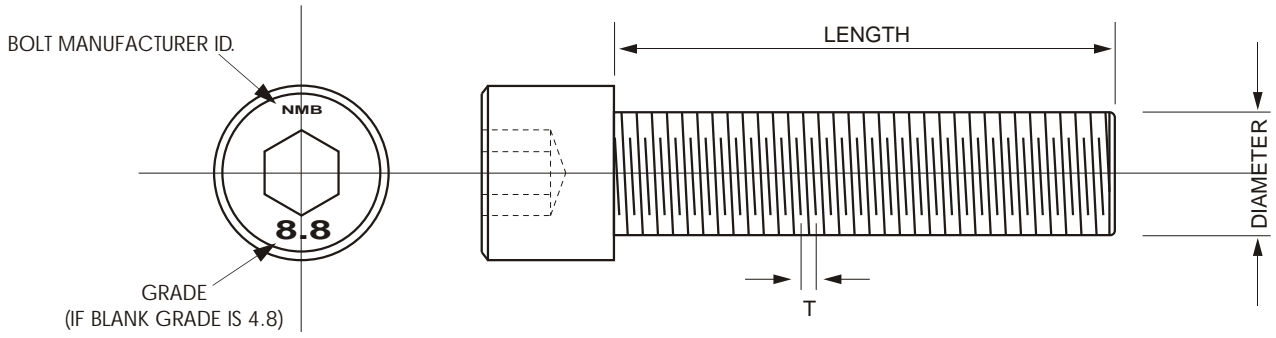

## METRIC BOLT

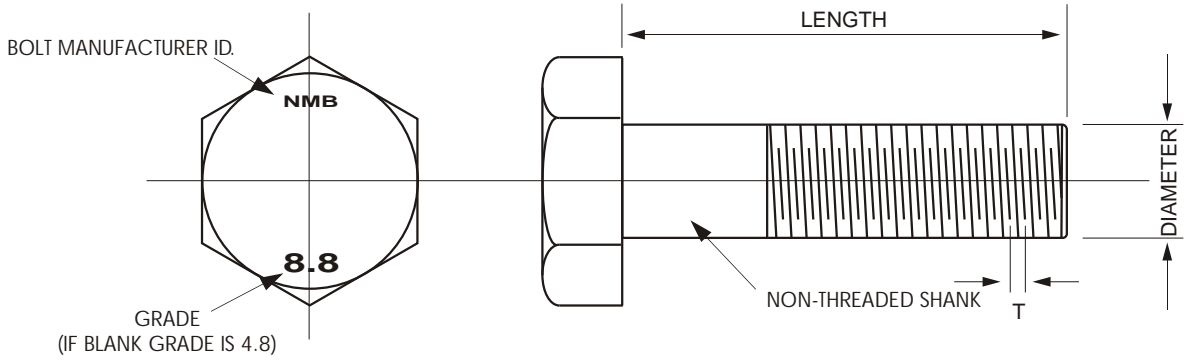

## Standard / SAE / USS BOLT

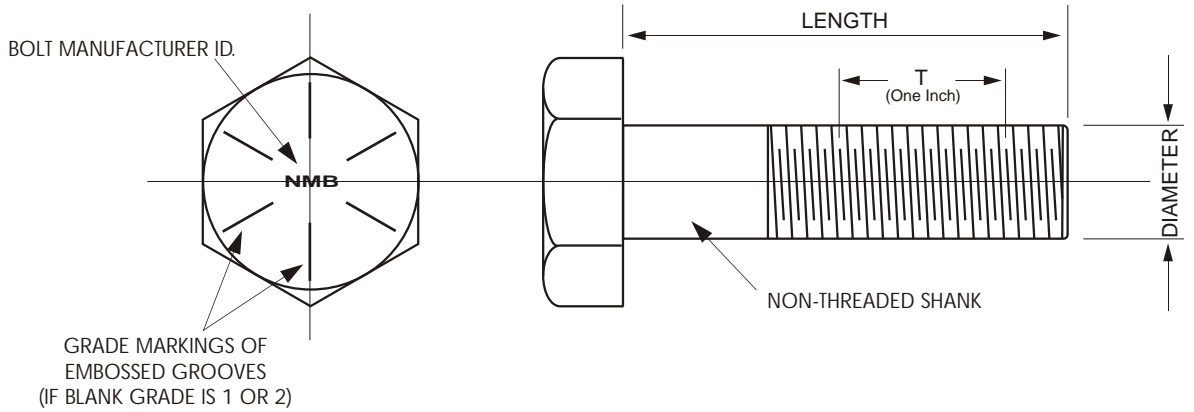

## METRIC NUT

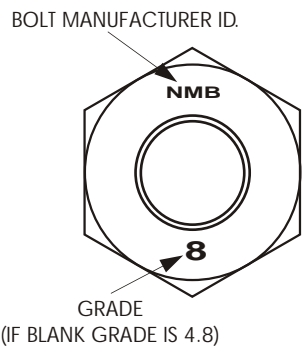

## Standard / SAE / USS NUT

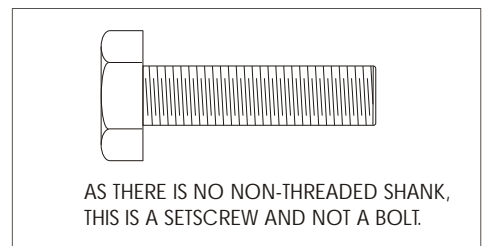
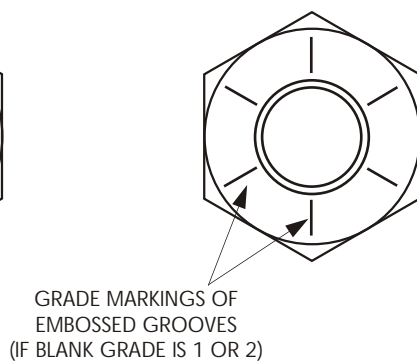

## DISASSEMBLY AND REASSEMBLY

Although this manual describes such procedures in detail it is a good habit to employ or note the following:

Ensure all fasteners are replaced in their original sequence and position. It is suggested that the disassembled components are laid out on a clean surface in the order that they were removed. If fasteners are only required at advanced stage it is advisable they are stored in clearly labelled plastic bags identifying their original location and sequence and if necessary, accompanied by written notes.

Take care with threads of any sort, especially those found in aluminium components as they may become stripped during reinstallation from accidental over tightening, or non-compatibility of fasteners.

## TOOLS

Building a Birkin from start to start to finish, requires a substantial selection of good quality tools. For the enthusiast who has few, purchasing the entire selection at the start may be too costly an exercise. In consideration of this fact, the tool list has been split up into smaller 'as needed' lists which are found on the page preceding each Group. Not only does this help spread the impact to one's budget, it also aids assembly preparation.

Even good quality tools need to be maintained. It is advisable to keep them clean and store them properly when not in use. Tools should never be left lying around the work area.

Should a tool become damaged or worn, it should be replaced to ensure that subsequent jobs will be safer and more enjoyable.

When using power tools, it is important to follow the manufacturers instructions and safety precautions.

## THE WORKING ENVIRONMENT

A suitable under cover work area is essential with a clean, flat workbench of comfortable working height. Clean, dry storage space will also be required for tools, fluids, lubricants and temporary placement of bodywork.

A supply of old newspaper, old towels, clean rags and paper towelling should be made available for mopping up spills or the protection of work surfaces.

A large cardboard box can be cut open, flattened and placed under your Birkin to protect the garage or workshop floor against accidental spills.

Always protect painted surfaces with a non abrasive material when working on or near them.

Whilst constructing it is advisable:

- \* that no jewellery be worn as it may scratch the paint and bodywork.
- \* to wear protective clothing, keeping long sleeves and other loose areas as well as long hair well out of the way of moving parts and power tools.
- \* to wear eye protection when using power tools.
- \* that no tools or other items should be left on or in the chassis or engine as they may either leave marks and scratches or, if forgotten, may cause damage or personal injury.
- \* to keep chemicals and fluids tightly sealed and out of reach from children.
- \* to work in sequence and ensure that everything is correctly assembled and tightened.
- \* for someone to check on you repeatedly if working alone cannot be avoided.
- \* to ensure that any hoist used has a safe working load rating adequate for the job and the manufacturers instructions are followed carefully.
- \* to remember that safe construction of your Birkin takes first priority as it affects you and others. When in doubt, seek professional advice.
- \* not to allow unattended children or animals around the working environment at any stage.

- \* not to rush or take shortcuts to finish a job.
- \* not to lift heavy parts alone.
- \* not to push on wrenches / spanners when loosening or tightening nuts and bolts, always pull it towards you. If this cannot be avoided, push with an open hand to prevent injury to knuckles.
- \* not to use loose fitting wrenches or other tools which may slip and cause injury.
- \* not to leave spilled oil/grease on the floor - it should be mopped up immediately to avoid injury.
- \* not to siphon toxic liquids such as petrol/gasoline, anti-freeze and brake fluid by mouth or allow them to remain in contact with skin.
- \* to use approved jack stands to support the weight of the vehicle and place them under the recommended lift or support points.

## **CAUTION!**

### **ASBESTOS**

Asbestos may be found in insulating, sealing and other products for example brake linings, brake bands etc. Inhalation of dust from such products is extremely hazardous and must be avoided .

### **FIRE**

Petrol/gasoline is extremely flammable and smoking or any kind of open flame around the workshop area should be strictly prohibited. Never use petrol/gasoline to clean parts, always use an approved safety solvent.

The battery ground (-) needs to be disconnected before any work can be done on any part of the fuel or electrical system.

Never spill fuel onto a hot engine or exhaust component and it is strongly advisable to have a fire extinguisher suitable for use on fuel and electrical fires readily available.

**NEVER** extinguish a fuel or electrical fire with water.

### **FUMES**

Certain fumes especially petrol/gasoline vapour is highly toxic and can quickly cause unconsciousness and even death if inhaled to an extent. The engine is never to be run when in an enclosed area such as the garage. Carbon monoxide is released via exhaust fumes and this gas is extremely poisonous. It is advisable to run the engine in open air or at least have the rear of the vehicle outside of the work area.

All draining or pouring of volatile fluids, petrol/gasoline or cleaning fluids or solvents should be done in a well ventilated area. Never use fluids from unmarked containers and always follow manufacturers instructions.

## THE BATTERY

A spark or a bare light bulb often give off a certain amount of hydrogen which is highly explosive and should not be exposed close to a battery. The battery ground (-) must be disconnected before any work is done on any part of the fuel or electrical system.

If possible, when charging the battery from an external source (this does not apply to a sealed or maintenance-free battery), the filler caps or cover need to be loosened to prevent the battery from bursting if charged at an excessive rate.

When adding water to a non maintenance-free battery or carrying a battery, care must be taken as the electrolyte even when diluted is very corrosive and should not be allowed in contact with clothing or skin.

It is advisable to wear eye protection when cleaning a battery to avoid the caustic deposits from entering your eyes.

## HOUSEHOLD CURRENT

When using tools that operate from the household current, ensure they are correctly connected to their plugs and where necessary, properly grounded. Electrical tools should not be used in damp conditions or in the near vicinity of fuel or fuel vapours.

## SECONDARY IGNITION SYSTEM VOLTAGE

Do not touch certain parts of the ignition system such as the spark plug wires when the engine is running or being cranked, especially if parts are damp or the insulation is defective, this can cause a severe electric shock. The secondary system voltage is much higher than the electronic ignition system and could prove fatal.

# RECOMMENDED CHASSIS SUPPORT STANDS

Do not use conventional engine or jack stands to raise the chassis to working height until the vehicles front and rear suspension, including shocks and springs have been fully completed. Until such time it is recommended that you use an approved set of trestle stands sufficient to support the weight of a complete vehicle. These stands must be placed on level ground and in the positions indicated below.

A diagram of trestles used in the factory may be found overleaf. This is displayed purely as an example for your convenience and should only be constructed by an approved metal fabricator. Do Not attempt to construct these at home.



The Birkin S3 is a comparatively light vehicle. It is important to bare this in mind when working on the chassis whilst it is on stands. A fair amount of force such as leaning on the chassis, attempting to loosen an extremely tight fastener or even torque a fastener is sufficient to cause the chassis to fall. Always get someone to help you secure the chassis should any force need be applied.

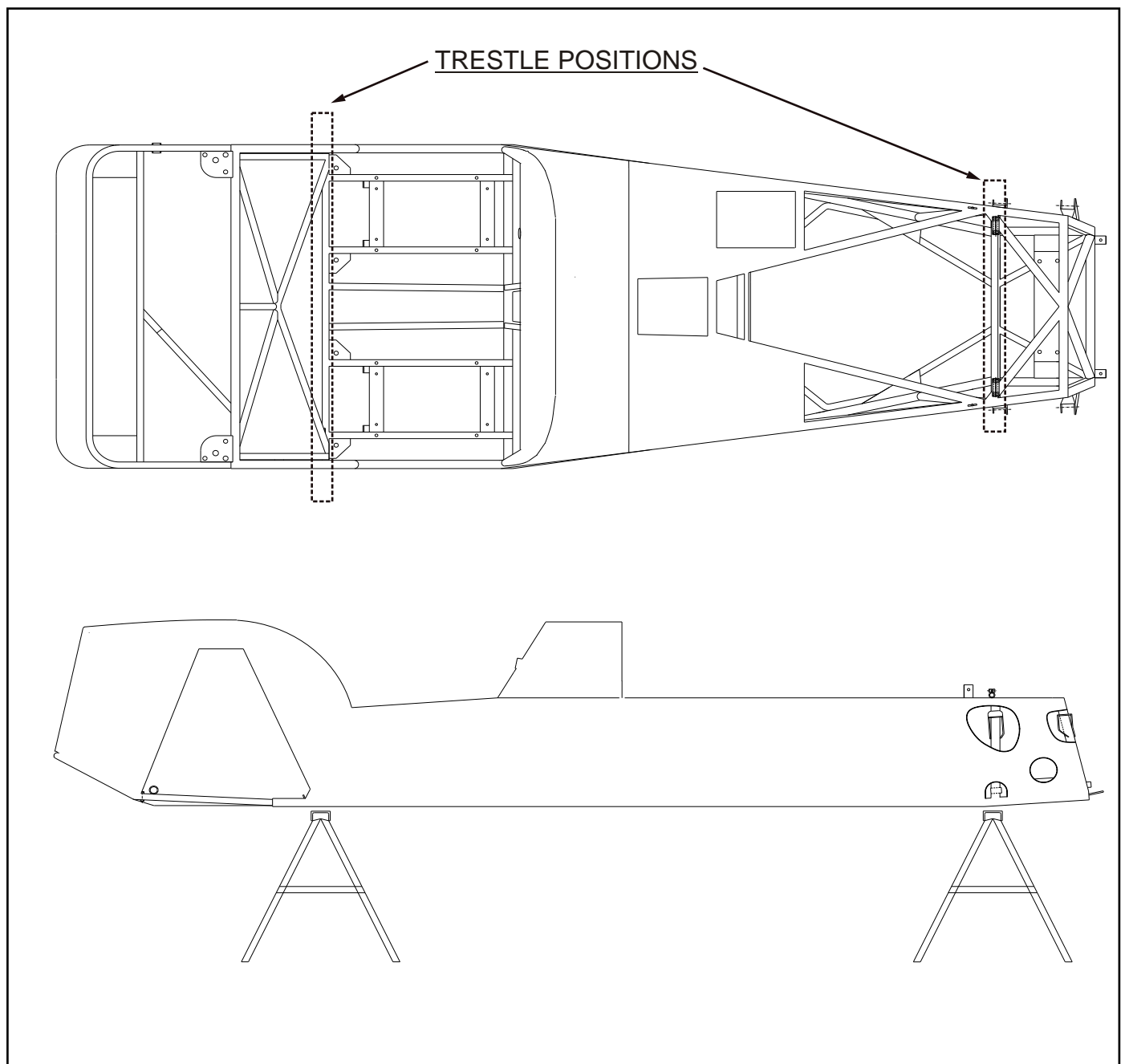

EXAMPLE OF TRESTLE STANDS USED FOR CHASSIS

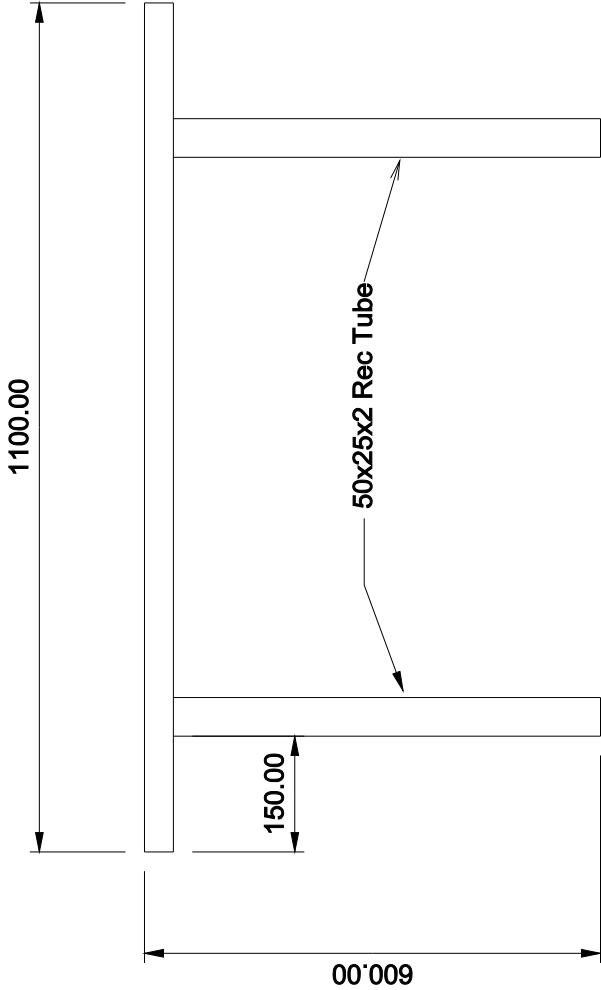
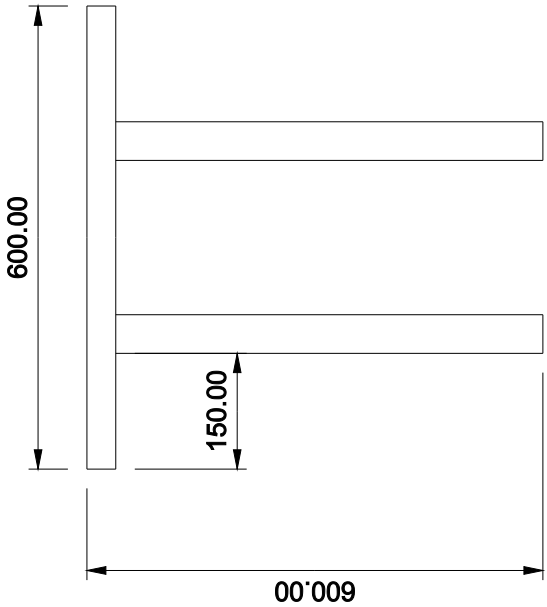
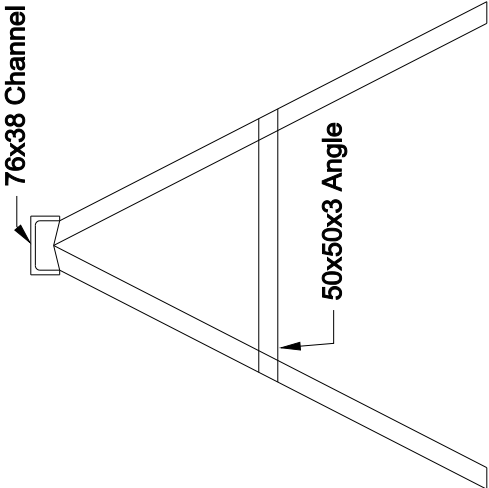
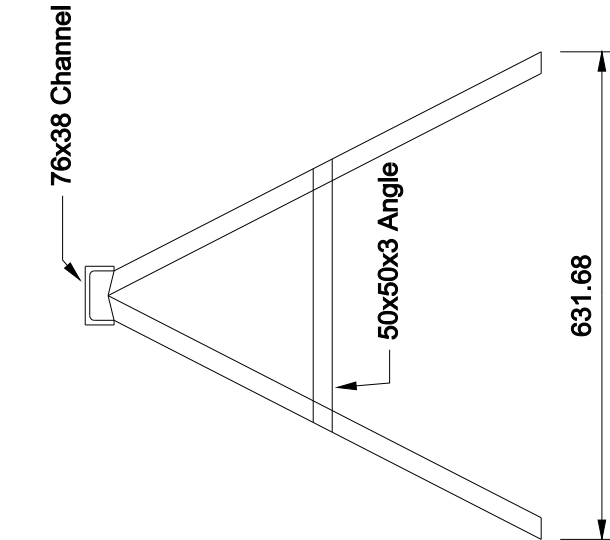

# CONVERSION FACTORS

## Length (distance)

Inches (in)	x 25.4 = Millimetres (mm)	x 0.0394 = Inches (in)
Feet (ft)	x 0.305 = Metres (m)	x 3.281 = Feet (ft)
Miles	x 1.609 = Kilometres (km)	x 0.621 = Miles

## Volume (capacity)

Cubic inches (cu in; in <sup>3</sup> )	x 16.387 = Cubic centimetres (cc; cm <sup>3</sup> )	x 0.061 = Cubic inches (cu in; in <sup>3</sup> )
Imperial pints (Imp pt)	x 0.568 = Litres (l)	x 1.76 = Imperial pints (Imp pt)
Imperial quarts (Imp qt)	x 1.137 = Litres (l)	x 0.88 = Imperial quarts (Imp qt)
Imperial quarts (Imp qt)	x 1.201 = US quarts (US qt)	x 0.833 = Imperial quarts (Imp qt)
US quarts (US qt)	x 0.946 = Litres (l)	x 1.057 = US quarts (US qt)
Imperial gallons (Imp gal)	x 4.546 = Litres (l)	x 0.22 = Imperial gallons (Imp gal)
Imperial gallons (Imp gal)	x 1.201 = US gallons (US gal)	x 0.833 = Imperial gallons (Imp gal)
US gallons (US gal)	x 3.785 = Litres (l)	x 0.264 = US gallons (US gal)

## Mass (weight)

Ounces (oz)	x 28.35 = Grams (g)	x 0.035 = Ounces (oz)
Pounds (lb)	x 0.454 = Kilograms (kg)	x 2.205 = Pounds (lb)

## Force

Ounces-force (ozf; oz)	x 0.278 = Newtons (N)	x 3.6 = Ounces-force (ozf; oz)
Pounds-force (lbf; lb)	x 4.448 = Newtons (N)	x 0.225 = Pounds-force (lbf; lb)
Newtons (N)	x 0.1 = Kilograms-force (kgf; kg)	x 9.81 = Newtons (N)

## Pressure

Pounds-force per square inch (psi; lbf/in <sup>2</sup> ; lb/in <sup>2</sup> )	x 0.070 = Kilograms-force per square centimetres (kgf/cm <sup>2</sup> ; kg/cm <sup>2</sup> )	x 14.223 = Pounds-force per square inch (psi; lbf/in <sup>2</sup> ; lb/in <sup>2</sup> )
Pounds-force per square inch (psi; lbf/in <sup>2</sup> ; lb/in <sup>2</sup> )	x 0.068 = Atmosphere (atm)	x 14.696 = Pounds-force per square inch (psi; lbf/in <sup>2</sup> ; lb/in <sup>2</sup> )
Pounds-force per square inch (psi; lbf/in <sup>2</sup> ; lb/in <sup>2</sup> )	x 0.069 = Bars	x 14.5 = Pounds-force per square inch (psi; lbf/in <sup>2</sup> ; lb/in <sup>2</sup> )
Pounds-force per square inch (psi; lbf/in <sup>2</sup> ; lb/in <sup>2</sup> )	x 6.895 = Kilopascals (kPa)	x 0.145 = Pounds-force per square inch (psi; lbf/in <sup>2</sup> ; lb/in <sup>2</sup> )
Kilopascals (kPa)	x 0.01 = Kilograms-force per square centimetre (kgf/cm <sup>2</sup> ; kg/cm <sup>2</sup> )	x 98.1 = Kilopascals (kPa)

## Torque (moment of force)

Pounds-force inches (lbf in; lb in)	x 1.152 = Kilograms-force centimetre (kgf cm; kg cm)	x 0.868 = Pounds-force inches (lbf in; lb in)
Pounds-force inches (lbf in; lb in)	x 0.113 = Newton metres (Nm)	x 8.85 = Pounds-force inches (lbf in; lb in)
Pounds-force inches (lbf in; lb in)	x 0.083 = Pounds-force feet (lbf ft; lb ft)	x 12 = Pounds-force inches (lbf in; lb in)
Pounds-force feet (lbf ft; lb ft)	x 0.138 = Kilograms-force metres (kgf m; kg m)	x 7.233 = Pounds-force feet (lbf ft; lb ft)
Pounds-force feet (lbf ft; lb ft)	x 1.356 = Newton metres (Nm)	x 0.738 = Pounds-force feet (lbf ft; lb ft)
Newton metres (Nm)	x 0.102 = Kilograms-force metres (kgf m; kg m)	x 9.804 = Newton metres (Nm)

## Vacuum

Inches mercury (in. Hg)	x 3.377 = Kilopascals (kPa)	x 0.2961 = Inches mercury
Inches mercury (in. Hg)	x 25.4 = Millimetres mercury (mm Hg)	x 0.094 = Inches mercury

## Power

Horsepower (hp)	x 745.7 = Watts (W)	x 0.0013 = Horsepower (hp)
-----------------	---------------------	----------------------------

## Velocity (speed)

Miles per hour (miles/hr; mph)	x 1.609 = Kilometres per hour (km/h; kph)	x 0.621 = Miles per hour (miles/hr; mph)
--------------------------------	-------------------------------------------	------------------------------------------

## Fuel consumption \*

Miles per gallon, Imperial (mpg)	x 0.354 = Kilometres per litre (km/l)	x 2.825 = Miles per gallon, Imperial (mpg)
Miles per gallon, US (mpg)	x 0.425 = Kilometres per litre (km/l)	x 2.352 = Miles per gallon, US (mpg)

## Temperature

Degrees Fahrenheit	= (°C x 1.8) + 32
Degrees Celsius (Degrees Centigrade; °C)	= (°F - 32) x 0.56

\*It is common practice to convert from miles per gallon (mpg) to litres/100 kilometres (l/100km), where mpg (Imperial) x l/100 km = 282 and mpg (US) x l/100 km = 235